

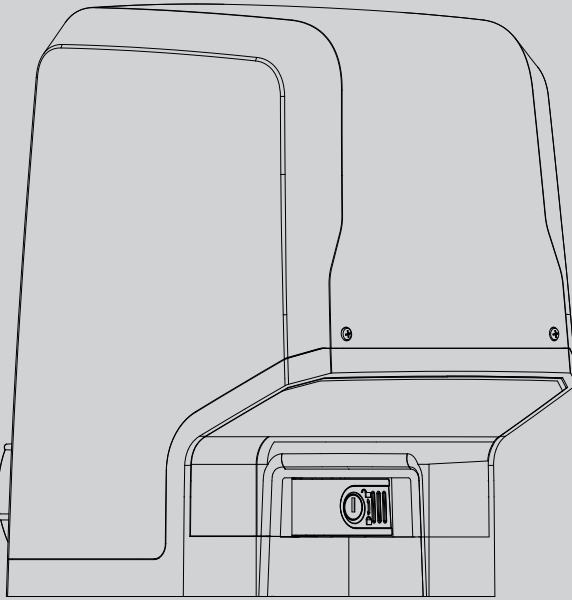

ac

D812860 00100_01 09-01-17

ATTUATORE PER CANCELLI SCORREVOLI A CREMAGLIERA
 ACTUATOR FOR RACK SLIDING GATES
 ACTIONNEUR POUR PORTAILS COULISSANTS A CREMAILLERE
 TRIEB FÜR SCHIEBETORE MIT ZAHNSTANGE
 SERVOMOTOR PARA CANCELAS CORREDERAS DE CREMALLERA
 ACTUATOR VOOR SCHUIFHEKKEN MET TANDHEUGEL



ISTRUZIONI D'USO E DI INSTALLAZIONE
 INSTALLATION AND USER'S MANUAL
 INSTRUCTIONS D'UTILISATION ET D'INSTALLATION
 INSTALLATIONS-UND GEBRAUCHSANLEITUNG
 INSTRUCCIONES DE USO Y DE INSTALACION
 INSTALLATIEVOORSCHRIFTEN

ICARO SMART AC A2000

ICARO ULTRA AC A2000

BFT



AZIENDA CON SISTEMA DI GESTIONE
 INTEGRATO CERTIFICATO DA DNV
 = UNI EN ISO 9001:2008 =
 UNI EN ISO 14001:2004

AVVERTENZE PER L'UTILIZZATORE (I)

ATTENZIONE! Importanti istruzioni di sicurezza. Leggere e seguire attentamente le Avvertenze e le Istruzioni che accompagnano il prodotto poiché un uso improprio può causare danni a persone, animali o cose. Conservare le istruzioni per consultazioni future e trasmetterle ad eventuali subentranti nell'uso dell'impianto.

Questo prodotto dovrà essere destinato solo all'uso per il quale è stato espressamente installato. Ogni altro uso è da considerarsi improprio e quindi pericoloso. Il costruttore non può essere considerato responsabile per eventuali danni causati da usi impropri, erronei e irragionevoli.

SICUREZZA GENERALE
Nel ringraziarVi per la preferenza accordata a questo prodotto, la Ditta è certa che da esso otterrete le prestazioni necessarie al Vostro uso.

Questo prodotto risponde alle norme riconosciute della tecnica e della disposizioni relative alla sicurezza se correttamente installato da personale qualificato ed esperto (installatore professionale). L'automazione, se installata ed utilizzata correttamente, soddisfa gli standard di sicurezza nell'uso. Tuttavia è opportuno osservare alcune regole di comportamento per evitare inconvenienti accidentali:

- Tenere bambini, persone e cose fuori dal raggio d'azione dell'automazione, in particolare durante il movimento.
- Non permettere a bambini di giocare o sostare nel raggio di azione dell'automazione.
- L'apparecchio può essere utilizzato da bambini di età non inferiore a 8 anni e da persone con ridotte capacità fisiche, sensoriali o mentali, o prive di esperienza o della necessaria conoscenza, purché sotto sorveglianza oppure dopo che le stesse abbiano ricevuto istruzioni relative all'uso sicuro dell'apparecchio e alla comprensione dei pericoli ad esso inerenti. I bambini non devono giocare con l'apparecchio. La pulizia e la manutenzione destinata ad essere effettuata dall'utilizzatore non deve essere effettuata da bambini senza sorveglianza.
- I bambini devono essere sorvegliati per sincerarsi che non giochino con l'apparecchio. Non permettere ai bambini di giocare con i controlli fissi. Tenere i telecomandi lontani dai bambini.
- Evitare di operare in prossimità delle cerniere o organi meccanici in movimento.
- Non contrastare il movimento dell'anta e non tentare di aprire manualmente la porta se non è stato sbloccato l'attuatore con l'apposito sblocco.
- Non entrare nel raggio di azione della porta o cancello motorizzati durante il loro movimento.
- Non lasciare radiocomandi o altri dispositivi di comando alla portata dei bambini onde evitare azionamenti involontari.
- L'attivazione dello sblocco manuale potrebbe causare movimenti incontrollati della porta se in presenza di guasti meccanici o di condizioni di squilibrio.
- In caso di apritapparelle: sorvegliare la tapparella in movimento e tenere lontano le persone finché non è completamente chiusa. Porre cura quando si aziona lo sblocco se presente, poiché una tapparella aperta potrebbe cadere rapidamente in presenza di usura o rotture.
- La rottura o l'usura di organi meccanici della porta (parte guidata), quali ad esempio cavi, molle, sup-

porti, cardini, guide.. potrebbe generare pericoli. Far controllare periodicamente l'impianto da personale qualificato ed esperto (installatore professionale) secondo quanto indicato dall'installatore o dal costruttore della porta.

- Per ogni operazione di pulizia esterna, togliere l'alimentazione di rete.
- Tenere pulite le ottiche delle fotocellule ed i dispositivi di segnalazione luminosa. Controllare che rami ed arbusti non disturbino i dispositivi di sicurezza.
- Non utilizzare l'automatismo se necessita di interventi di riparazione. In caso di guasto o di malfunzionamento dell'automazione, togliere l'alimentazione di rete sull'automazione, astenersi da qualsiasi tentativo di riparazione o intervento diretto e rivolgersi solo a personale qualificato ed esperto (installatore professionale) per la necessaria riparazione o manutenzione. Per consentire l'accesso, attivare lo sblocco di emergenza (se presente).
- Per qualsiasi intervento diretto sull'automazione o sull'impianto non previsto dal presente manuale, avvalersi di personale qualificato ed esperto (installatore professionale).
- Con frequenza almeno annuale far verificare l'integrità e il corretto funzionamento dell'automazione da personale qualificato ed esperto (installatore professionale), in particolare di tutti i dispositivi di sicurezza.
- Gli interventi d'installazione, manutenzione e riparazione devono essere documentati e la relativa documentazione tenuta a disposizione dell'utilizzatore.
- Il mancato rispetto di quanto sopra può creare situazioni di pericolo.



DEMOLIZIONE

L'eliminazione dei materiali va fatta rispettando le norme vigenti. Non gettate il vostro apparecchio scartato, le pile o le batterie usate nei rifiuti domestici. Avete la responsabilità di restituire tutti i vostri rifiuti da apparecchiature elettriche o elettroniche lasciandoli in un punto di raccolta dedicato al loro riciclo.

Tutto quello che non è espressamente previsto nel manuale d'uso, non è permesso. Il buon funzionamento dell'operatore è garantito solo se vengono rispettate le prescrizioni riportate in questo manuale. La Ditta non risponde dei danni causati dall'inosservanza delle indicazioni riportate in questo manuale.

Lasciando inalterate le caratteristiche essenziali del prodotto, la Ditta si riserva di apportare in qualunque momento le modifiche che essa ritiene convenienti per migliorare tecnicamente, costruttivamente e commercialmente il prodotto, senza impegnarsi ad aggiornare la presente pubblicazione.

USER WARNINGS (GB)

WARNING! Important safety instructions. Carefully read and comply with the Warnings and Instructions that come with the product as improper use can cause injury to people and animals and damage to property. Keep the instructions for future reference and hand them on to any new users.

This product is meant to be used only for the purpose for which it was explicitly installed.



Any other use constitutes improper use and, consequently, is hazardous. The manufacturer cannot be held liable for any damage as a result of improper, incorrect or unreasonable use.

GENERAL SAFETY

Thank you for choosing this product. The Firm is confident that its performance will meet your operating needs.

This product meets recognized technical standards and complies with safety provisions when installed correctly by qualified, expert personnel (professional installer).

If installed and used correctly, the automated system will meet operating safety standards. Nonetheless, it is advisable to observe certain rules of behaviour so that accidental problems can be avoided:

- Keep adults, children and property out of range of the automated system, especially while it is moving.
- Do not allow children to play or stand within range of the automated system.
- The unit can be used by children over 8 years old and by people with reduced physical, sensory or mental capabilities or with no experience or necessary knowledge on condition they are supervised or trained about the safe use of the equipment and understand the risks involved. Children must not play with the unit. Cleaning and maintenance must not be performed by unsupervised children.
- Children must be supervised to ensure they do not play with the device. Do not allow children to play with the fixed controls. Keep remote controls out of reach of children.
- Do not work near hinges or moving mechanical parts.
- Do not hinder the leaf's movement and do not attempt to open the door manually unless the actuator has been released with the relevant release knob.
- Keep out of range of the motorized door or gate while they are moving.
- Keep remote controls or other control devices out of reach of children in order to avoid the automated system being operated inadvertently.
- The manual release's activation could result in uncontrolled door movements if there are mechanical faults or loss of balance.
- When using roller shutter openers: keep an eye on the roller shutter while it is moving and keep people away until it has closed completely. Exercise care when activating the release, if such a device is fitted, as an open shutter could drop quickly in the event of wear or breakage.
- The breakage or wear of any mechanical parts of the door (operated part), such as cables, springs, supports, hinges, guides... , may generate a hazard. Have the system checked by qualified, expert personnel (professional installer) at regular intervals according to the instructions issued by the installer or manufacturer of the door.
- When cleaning the outside, always cut off mains power.
- Keep the photocells' optics and illuminating indicator devices clean. Check that no branches or shrubs interfere with the safety devices.
- Do not use the automated system if it is in need of repair. In the event the automated system breaks down or malfunctions, cut off mains power to the system; do not attempt to repair or perform any other work to rectify the fault yourself and instead call in qualified, expert personnel (professional installer) to perform the necessary repairs or main-

tenance. To allow access, activate the emergency release (where fitted).

- If any part of the automated system requires direct work of any kind that is not contemplated herein, employ the services of qualified, expert personnel (professional installer).
- At least once a year, have the automated system, and especially all safety devices, checked by qualified, expert personnel (professional installer) to make sure that it is undamaged and working properly.
- A record must be made of any installation, maintenance and repair work and the relevant documentation kept and made available to the user on request.
- Failure to comply with the above may result in hazardous situations.



SCRAPPING

Materials must be disposed of in accordance with the regulations in force. Do not throw away your discarded equipment or used batteries with household waste. You are responsible for taking all your waste electrical and electronic equipment to a suitable recycling centre.

Anything that is not explicitly provided for in the user guide is not allowed. The operator's proper operation can only be guaranteed if the instructions given herein are complied with. The Firm shall not be answerable for damage caused by failure to comply with the instructions featured herein.

While we will not alter the product's essential features, the Firm reserves the right, at any time, to make those changes deemed opportune to improve the product from a technical, design or commercial point of view, and will not be required to update this publication accordingly.

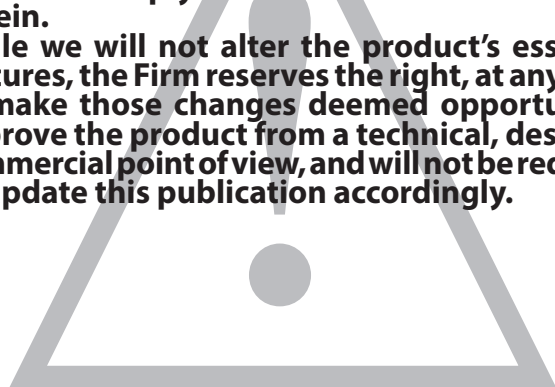
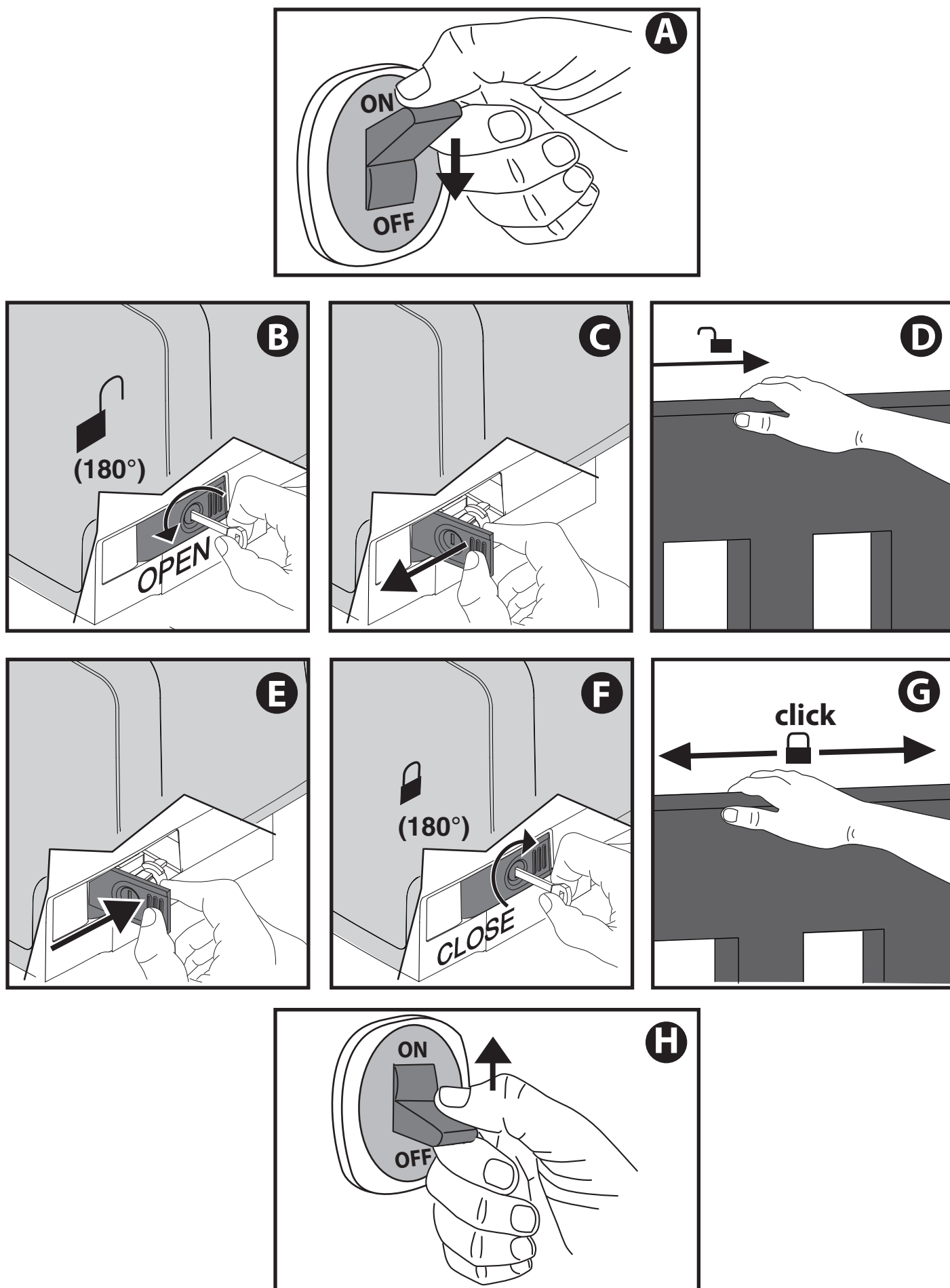

FIG. 2



INSTALLER WARNINGS

WARNING! Important safety instructions. Carefully read and comply with all the warnings and instructions that come with the product as incorrect installation can cause injury to people and animals and damage to property. The warnings and instructions give important information regarding safety, installation, use and maintenance. Keep hold of instructions so that you can attach them to the technical file and keep them handy for future reference.

GENERAL SAFETY

This product has been designed and built solely for the purpose indicated herein. Uses other than those indicated herein might cause damage to the product and create a hazard.

- The units making up the machine and its installation must meet the requirements of the following European Directives, where applicable: 2014/30/EC, 2014/35/EC, 2006/42/EC, 2011/305/EC, 99/05/EC and later amendments. For all countries outside the EEC, it is advisable to comply with the standards mentioned, in addition to any national standards in force, to achieve a good level of safety.
- The Manufacturer of this product (hereinafter referred to as the "Firm") disclaims all responsibility resulting from improper use or any use other than that for which the product has been designed, as indicated herein, as well as for failure to apply Good Practice in the construction of entry systems (doors, gates, etc.) and for deformation that could occur during use.
- Installation must be carried out by qualified personnel (professional installer, according to EN 12635), in compliance with Good Practice and current code.
- Before installing the product, make all structural changes required to produce safety gaps and to provide protection from or isolate all crushing, shearing and dragging hazard areas and danger zones in general in accordance with the provisions of standards EN 12604 and 12453 or any local installation standards. Check that the existing structure meets the necessary strength and stability requirements.
- Before commencing installation, check the product for damage.
- The Firm is not responsible for failure to apply Good Practice in the construction and maintenance of the doors, gates, etc. to be motorized, or for deformation that might occur during use.
- Make sure the stated temperature range is compatible with the site in which the automated system is due to be installed.
- Do not install this product in an explosive atmosphere: the presence of flammable fumes or gas constitutes a serious safety hazard.
- Disconnect the electricity supply before performing any work on the system. Also disconnect buffer batteries, if any are connected.
- Before connecting the power supply, make sure the product's ratings match the mains ratings and that a suitable residual current circuit breaker and overcurrent protection device have been installed upline from the electrical system. Have the automated system's mains power supply fitted with a switch or omnipolar thermal-magnetic circuit breaker with a contact separation that provide full disconnection under overvoltage category III conditions.
- Make sure that upline from the mains power supply there is a residual current circuit breaker that trips at no more than 0.03A as well as any other equipment required by code.
- Make sure the earth system has been installed correctly: earth all the metal parts belonging to the entry system (doors, gates, etc.) and all parts of the system featuring an earth terminal.
- Installation must be carried out using safety devices and controls that meet standards EN 12978 and EN 12453.
- Impact forces can be reduced by using deformable edges.
- In the event impact forces exceed the values laid down by the relevant standards, apply electro-sensitive or pressure-sensitive devices.
- Apply all safety devices (photocells, safety edges, etc.) required to keep the area free of impact, crushing, dragging and shearing hazards. Bear in mind the standards and directives in force, Good Practice criteria, intended use, the installation environment, the operating logic of the system and forces generated by the automated system.
- Apply all signs required by current code to identify hazardous areas (residual risks). All installations must be visibly identified in compliance with the provisions of standard EN 13241-1.
- Once installation is complete, apply a nameplate featuring the door/gate's data.
- This product cannot be installed on leaves incorporating doors (unless the motor can be activated only when the door is closed).
- If the automated system is installed at a height of less than 2.5 m or is accessible, the electrical and mechanical parts must be suitably protected.
- For roller shutter automation only
 - 1) The motor's moving parts must be installed at a height greater than 2.5 m above the floor or other surface from which they may be reached.
 - 2) The gearmotor must be installed in a segregated and suitably protected space so that it cannot be reached without the aid of tools.
- Install any fixed controls in a position where they will not cause a hazard, away from moving parts. More specifically, hold-to-run controls must be positioned within direct sight of the part being controlled and, unless they are key operated, must be installed at a height of at least 1.5 m and in a place where they cannot be reached by the public.
- Apply at least one warning light (flashing light) in a visible position, and also attach a Warning sign to the structure.
- Attach a label near the operating device, in a permanent fashion, with information on how to operate the automated system's manual release.
- Make sure that, during operation, mechanical risks are avoided or relevant protective measures taken and, more specifically, that nothing can be banged, crushed, caught or cut between the part being operated and surrounding parts.
- Once installation is complete, make sure the motor automation settings are correct and that the safety and release systems are working properly.
- Only use original spare parts for any maintenance or repair work. The Firm disclaims all responsibility for the correct operation and safety of the automated system if parts from other manufacturers are used.
- Do not make any modifications to the automated system's components unless explicitly authorized by the Firm.
- Instruct the system's user on what residual risks may be encountered, on the control systems that have been applied and on how to open the system manually in an emergency. Give the user guide to the end user.

-Dispose of packaging materials (plastic, cardboard, polystyrene, etc.) in accordance with the provisions of the laws in force. Keep nylon bags and polystyrene out of reach of children.

WIRING

WARNING! For connection to the mains power supply, use a multicore cable with a cross-sectional area of at least 5x1.5mm² or 4x1.5mm² when dealing with three-phase power supplies or 3x1.5mm² for single-phase supplies (by way of example, type H05RN-F cable can be used with a cross-sectional area of 4x1.5mm²). To connect auxiliary equipment, use wires with a cross-sectional area of at least 0.5 mm².

- Only use pushbuttons with a capacity of 10A-250V or more.
- Wires must be secured with additional fastening near the terminals (for example, using cable clamps) in order to keep live parts well separated from safety extra low voltage parts.
- During installation, the power cable must be stripped to allow the earth wire to be connected to the relevant terminal, while leaving the live wires as short as possible. The earth wire must be the last to be pulled taut in the event the cable's fastening device comes loose.

WARNING! safety extra low voltage wires must be kept physically separate from low voltage wires.

Only qualified personnel (professional installer) should be allowed to access live parts.

CHECKING THE AUTOMATED SYSTEM AND MAINTENANCE

Before the automated system is finally put into operation, and during maintenance work, perform the following checks meticulously:

- Make sure all components are fastened securely.
- Check starting and stopping operations in the case of manual control.
- Check the logic for normal or personalized operation.
- For sliding gates only: check that the rack and pinion mesh correctly with 2 mm of play along the full length of the rack; keep the track the gate slides on clean and free of debris at all times.
- For sliding gates and doors only: make sure the gate's running track is straight and horizontal and that the wheels are strong enough to take the weight of the gate.
- For cantilever sliding gates only: make sure there is no dipping or swinging during operation.
- For swing gates only: make sure the leaves' axis of rotation is perfectly vertical.
- For barriers only: before opening the door, the spring must be decompressed (vertical boom).
- Check that all safety devices (photocells, safety edges, etc.) are working properly and that the anti-crush safety device is set correctly, making sure that the force of impact measured at the points provided for by standard EN 12445 is lower than the value laid down by standard EN 12453.
- Impact forces can be reduced by using deformable edges.
- Make sure that the emergency operation works, where this feature is provided.
- Check opening and closing operations with the control devices applied.
- Check that electrical connections and cabling are intact, making extra sure that insulating sheaths and cable glands are undamaged.
- While performing maintenance, clean the photocells' optics.
- When the automated system is out of service for any length of time, activate the emergency release (see "EMERGENCY OPERATION" section) so that the operated part is made idle, thus allowing the gate to be opened and closed manually.
- If the power cord is damaged, it must be replaced by the manufacturer or their technical assistance department or other such qualified person to avoid any risk.
- If "D" type devices are installed (as defined by EN12453), connect in unverified mode, foresee mandatory maintenance at least every six months
- The maintenance described above must be repeated at least once yearly or at shorter intervals where site or installation conditions make this necessary.

WARNING!

Remember that the drive is designed to make the gate/door easier to use and will not solve problems as a result of defective or poorly performed installation or lack of maintenance



SCRAPPING

Materials must be disposed of in accordance with the regulations in force. Do not throw away your discarded equipment or used batteries with household waste. You are responsible for taking all your waste electrical and electronic equipment to a suitable recycling centre.

DISMANTLING

If the automated system is being dismantled in order to be reassembled at another site, you are required to:

- Cut off the power and disconnect the whole electrical system.
- Remove the actuator from the base it is mounted on.
- Remove all the installation's components.
- See to the replacement of any components that cannot be removed or happen to be damaged.

**DECLARATIONS OF CONFORMITY CAN BE FOUND AT <http://www.bft-automation.com/CE>
INSTRUCTIONS FOR USE AND ASSEMBLY CAN BE FOUND IN THE DOWN-LOAD SECTION.**

Anything that is not explicitly provided for in the installation manual is not allowed. The operator's proper operation can only be guaranteed if the information given is complied with. The Firm shall not be answerable for damage caused by failure to comply with the instructions featured herein.

While we will not alter the product's essential features, the Firm reserves the right, at any time, to make those changes deemed opportune to improve the product from a technical, design or commercial point of view, and will not be required to update this publication accordingly.

INSTALLAZIONE VELOCE-QUICK INSTALLATION-INSTALLATION RAPIDE SCHNELLINSTALLATION-INSTALACIÓN RÁPIDA - SNELLE INSTALLATIE

ITALIANO

ENGLISH

FRANÇAIS

DEUTSCH

ESPAÑOL

NEDERLANDS

A

PREDISPOSIZIONE TUBI, TUBE ARRANGEMENT,
PRÉDISPOSITION DES TUYAUX, VORBEREITUNG DER LEITUNGEN,
DISPOSICIÓN DE TUBOS, VOORBEREIDING LEIDINGEN.

B

PREDISPOSIZIONE FISSAGGIO MOTORE,
PREPARATION FOR MOTOR MOUNTING,
AMÉNAGEMENT FIXATION MOTEUR,
VORBEREITUNG MOTORBEFESTIGUNG,
DISPOSICIÓN FIJACIÓN DEL MOTOR,
VOORBEREIDING BEVESTIGING MOTOR.

"X" = Cremagliera, Rack,
Crémaillère, Zahnstange,
Cremallera, Tandheugel

C

MONTAGGIO MOTORE, MOUNTING THE MOTOR, MONTAGE MOTEUR, MONTAGE MOTOR,
MONTAJE DEL MOTOR, MONTAGE MOTOR.

1

2

3

click

V2

C1

> 3mm

**MONTAGGIO ACCESSORI TRASMISSIONE,
MOUNTING DRIVE ACCESSORIES,
MONTAGE ACCESSOIRES TRANSMISSION,
MONTAGE ANTRIEBSZUBEHÖR,
MONTAJE DE ACCESORIOS TRANSMISIÓN,
MONTAGE ACCESSOIRES OVERBRENGING.**

D

D1

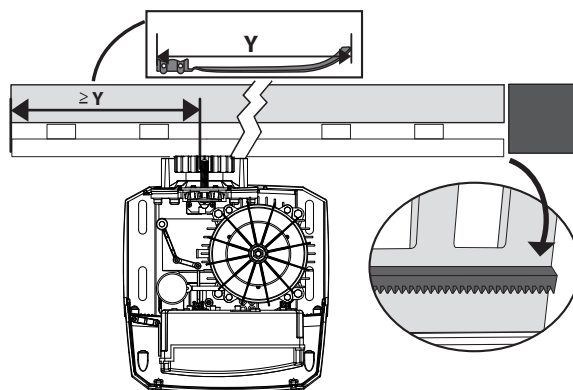
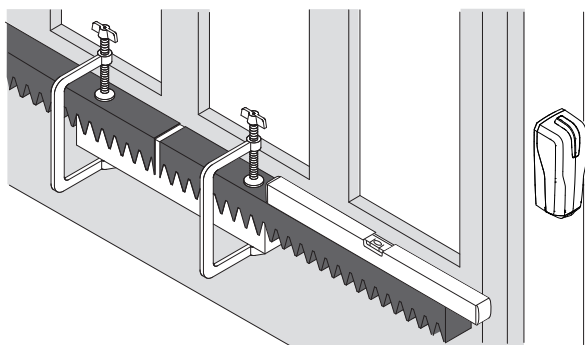

Solo per: / only for: / uniquement sur: / nur für: / solo para: / apenas para: ICARO SMART AC A2000

**FISSAGGIO STAFFE FINECORSA (DX E SX), FASTENING LIMIT SWITCH BRACKETS (RH/LH),
FIXATION ÉTRIERS FIN DE COURSE (DRT ET GCH), BEFESTIGUNG BÜGEL ANSCHLÄGE (RECHTS UND LINKS),
FIJACIÓN ABRAZADERAS FINAL DE CARRERA (DER. E IZQ.), BEVESTIGING STANGEN AANSLAG (RECHTS EN LINKS).**

E1

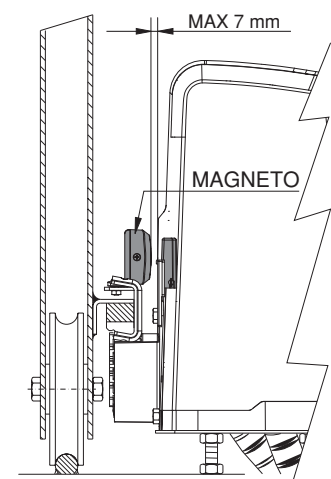
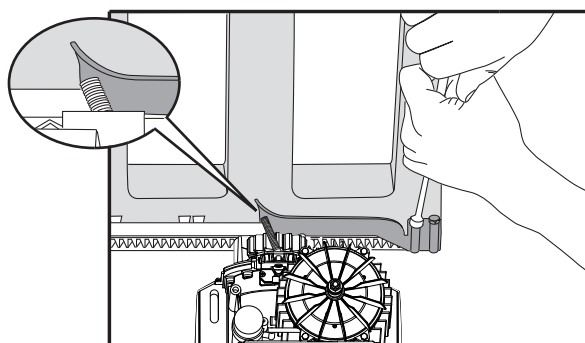
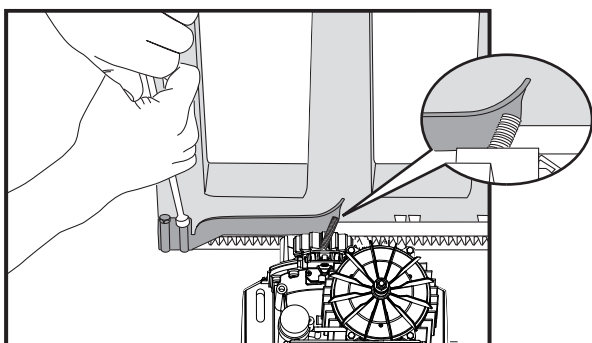

E2

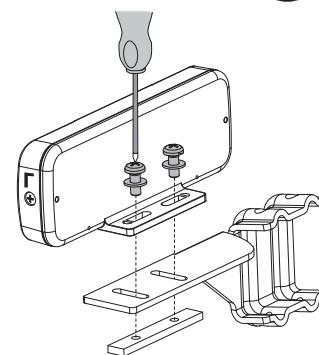
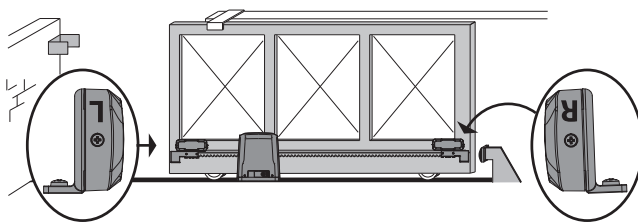

**COLLEGAMENTO MORSETTIERA, TERMINAL BOARD WIRING, CONNEXION PLAQUE À BORNES,
ANSCHLUSS KLEMMLEISTE, CONEXIÓN TABLERO DE BORNES, AANSLUITING AANSLUITKAST.**

F

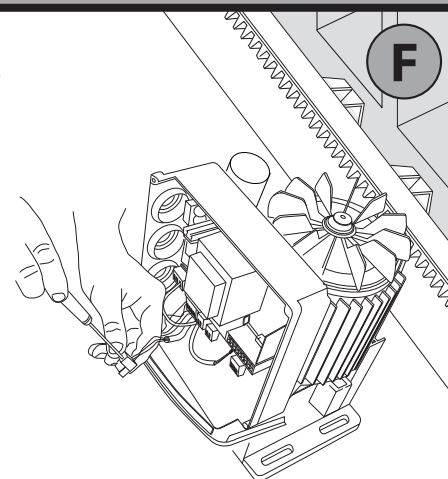
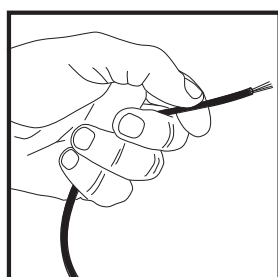
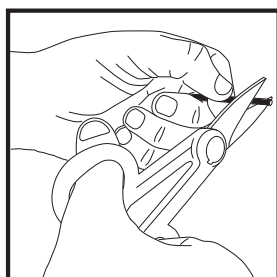

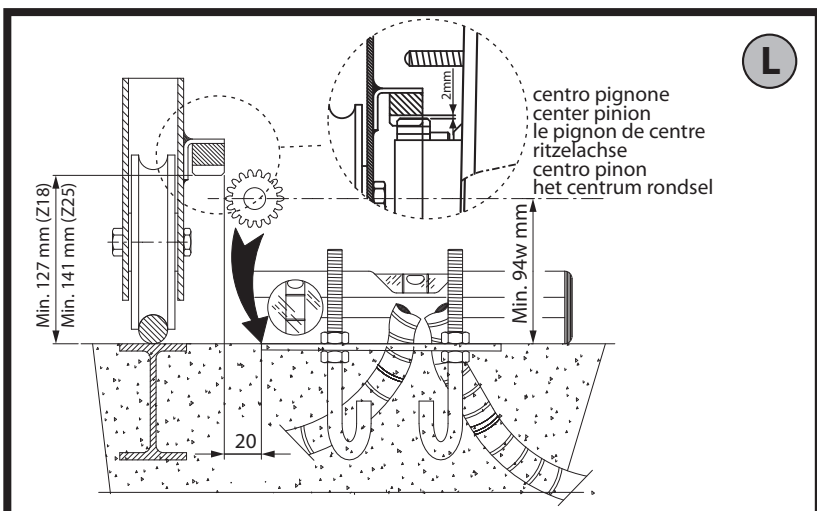
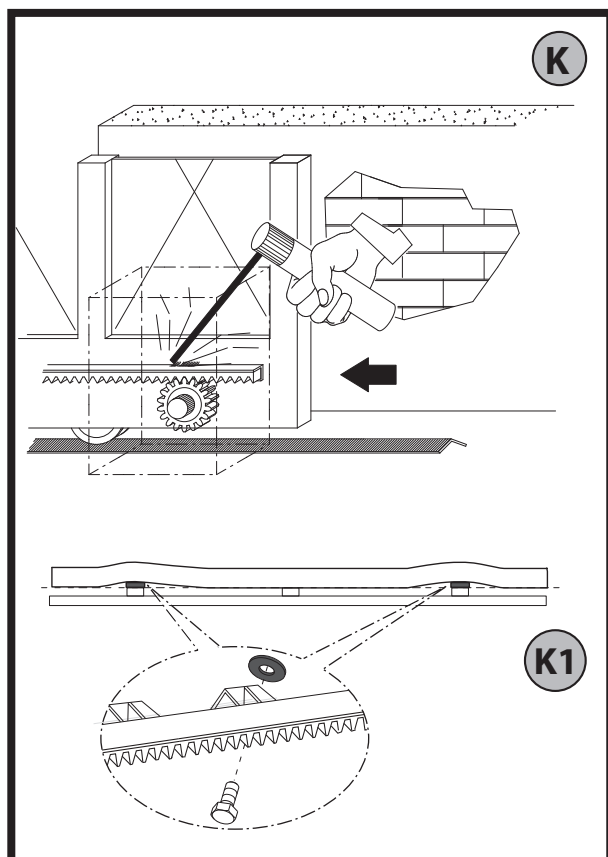
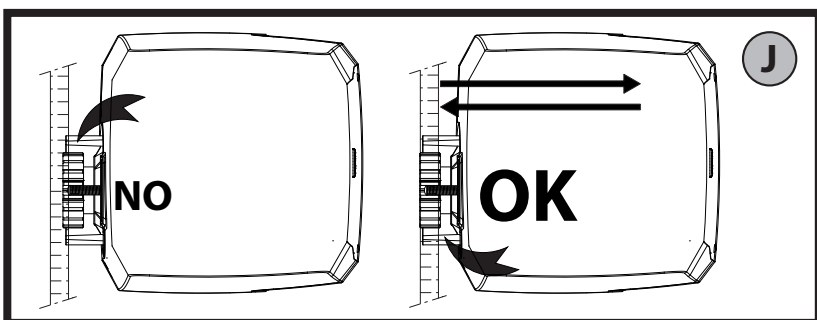
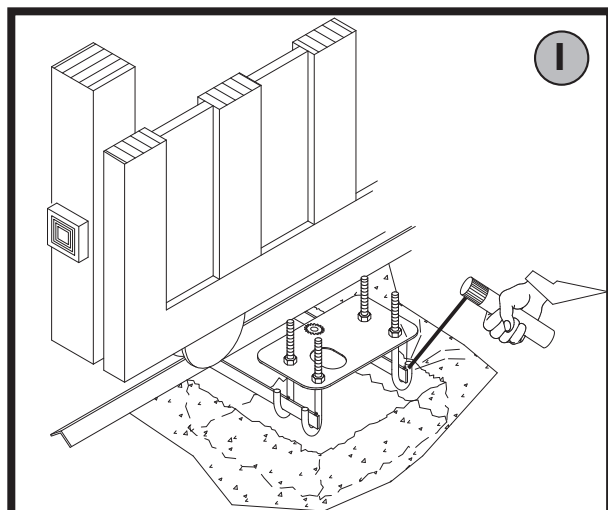
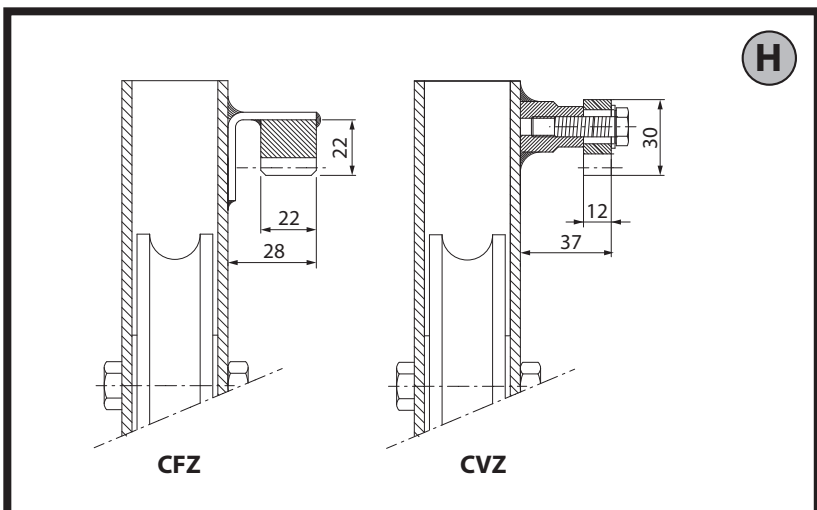
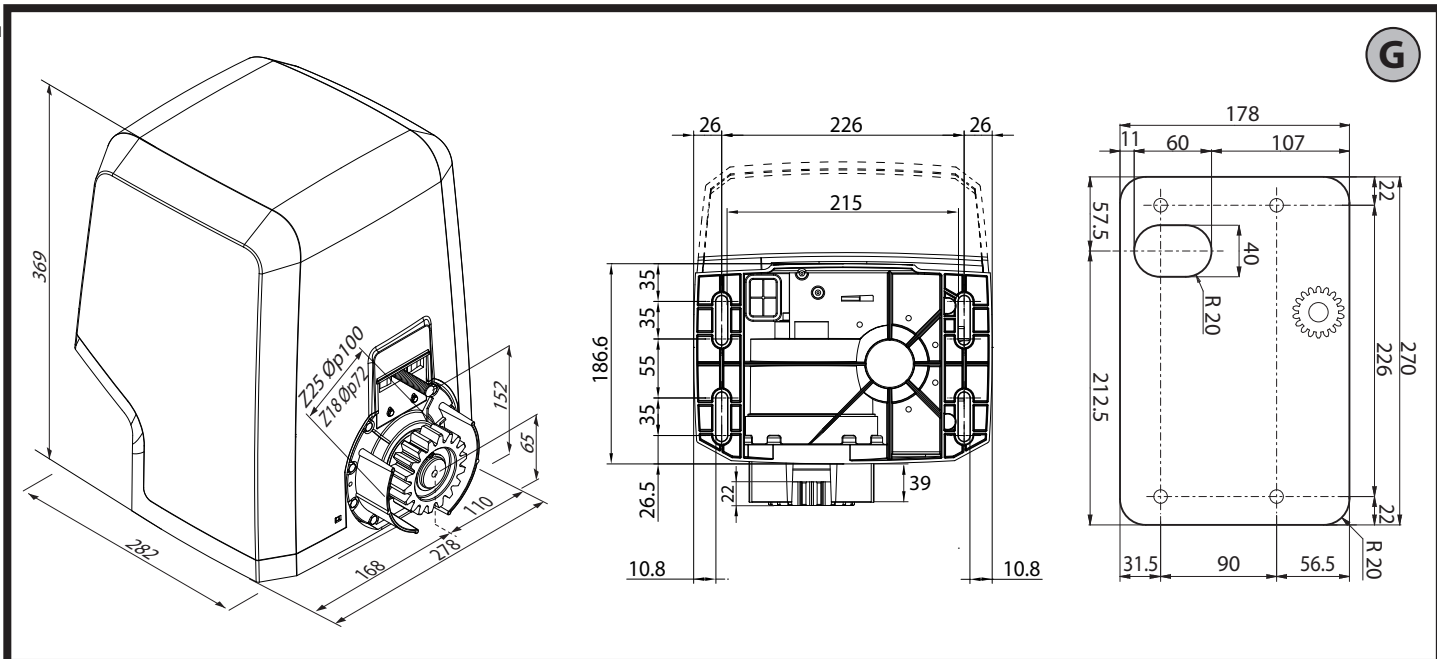

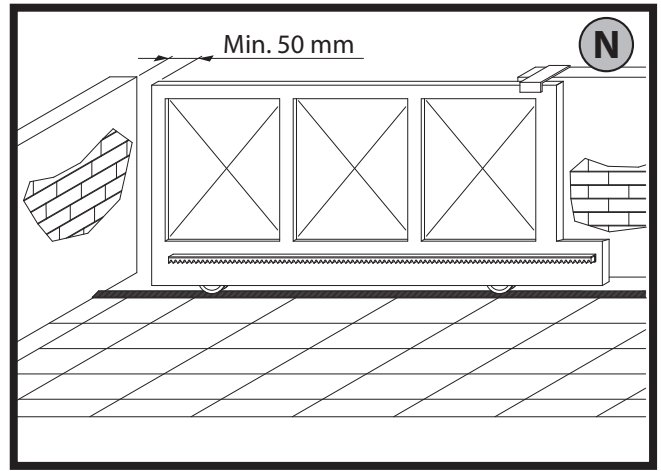
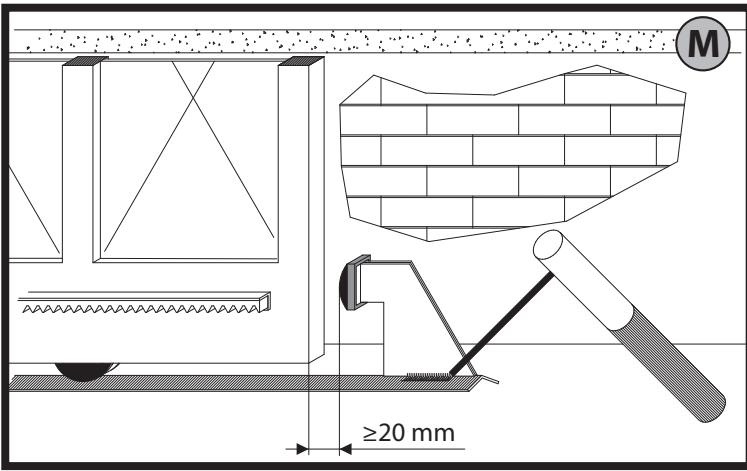

Solo per:
only for:
uniquement sur :
nur für:
solo para:
apenas para:
ICARO SMART AC A2000

R	M	N
ROSSO	MARRONE	NERO
RED	BROWN	BLACK
ROUGE	MARRON	NOIR
ROT	BRAUN	NERO
ROJO	MARON	NEGRO
ROOD	BRUIN	ZWART

O

M	B	N
MARRONE	BLU	NERO
BROWN	BLUE	BLACK
MARRON	BLEU	NOIR
BRAUN	BLAU	SCHWARZ
MARRÓN	AZUL	NEGRO
BRUIN	BLAUW	ZWART

ICARO ULTRA AC A2000:

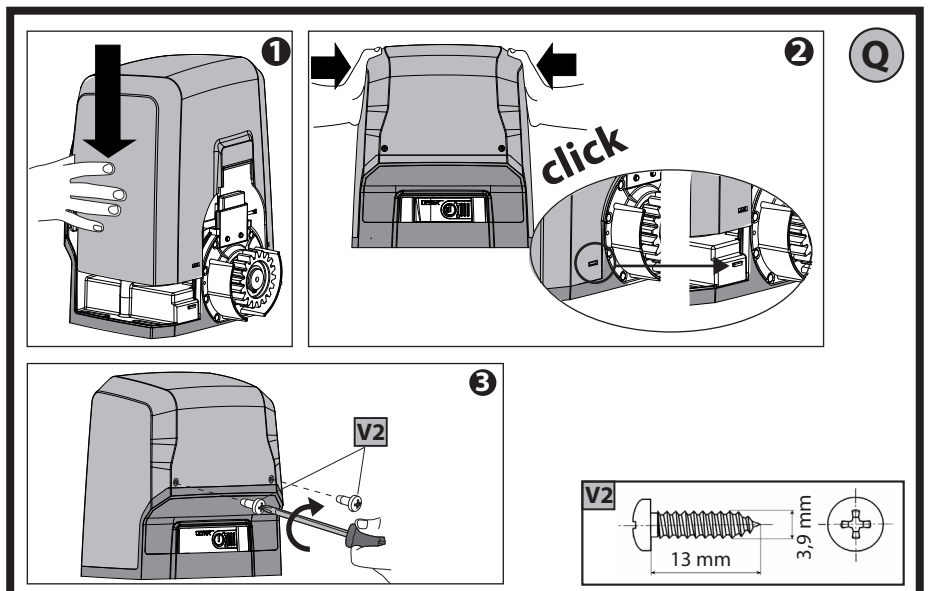
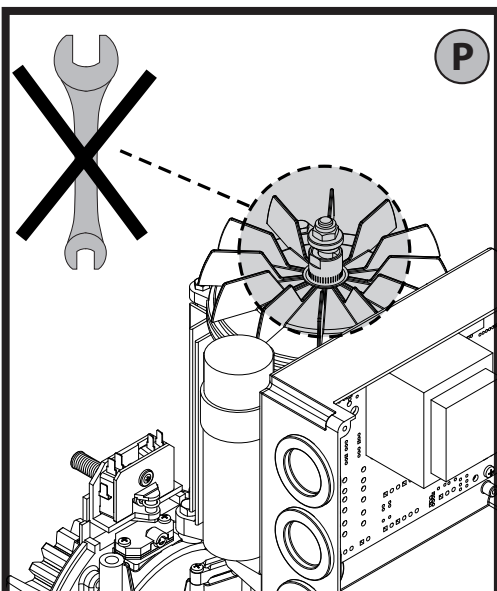

1) FOREWORD

The **ICARO SMART AC A2000** actuator offers ample installation versatility, thanks to the extremely low position of the pinion, the compactness of the actuator and to the height and depth which can be very easily adjusted. It is equipped with an clutch unit between motor shaft and worm screw in an oil bath to guarantee greater safety. Manual emergency operation is extremely easy to perform using just a lever.

The gate stop is controlled by electromechanical end-of-stroke microswitches or, for very cold areas, by proximity sensors (**ICARO ULTRA AC A2000**).

The control board can be built-in or installed onto a separate cabinet.

 "Installation must be carried out by qualified personnel (professional installer, according to EN 12635), in compliance with Good Practice and current code"

2) TECHNICAL SPECIFICATIONS

MOTOR	
Power supply/ Motor	ICARO SMART AC A2000/ICARO ULTRA AC A2000 220-230V 50/60 Hz
	ICARO SMART AC A2000 120V 110-120V 50/60 Hz
Power input	750W
Pinion module	4 mm (18 or 25 teeth)
Leaf speed	ICARO SMART AC A2000/ICARO ULTRA AC A2000 9m/min (18 teet)
	ICARO SMART AC A2000 V 12m/min (25 teeth)
Max. leaf weight	ICARO SMART AC A2000/ICARO ULTRA AC A2000 with pinion Z18 20.000 N(≈2000 kg)
	ICARO SMART AC A2000 V with pinion Z25 10.000 N(≈1000 kg)
Max. torque	40Nm
Impact reaction	IObstacle detection device (Encoder)
Lubrication	ERGOIL
Manual operation	Lever-operated mechanical release
Type of use	very intensive
Environmental conditions	from -15°C to +55°C
Protection rating	ICAROSMARTACA2000/ICAROSMARTACA2000120V IP24
	ICARO ULTRA AC A2000 IP55
Noise level	<70dBA
Operator weight	25 kg
Dimensions	See Fig. G

3) TUBE ARRANGEMENT Fig.A

Install the electrical system referring to the standards in force for electrical systems CEI 64-8, IEC 364, harmonization document HD 384 and other national standards.

4) PREPARATION FOR MOTOR MOUNTING FIG.B

- Make a hole in the ground to accommodate the concrete pad, with anchors embedded in the base plate for fastening the gearbox assembly, keeping to the distances featured in **FIG.B**.
- To keep the base plate in the right position during installation, it may be useful to weld two iron plates under the track to which the anchors can then be welded (**FIG.I**).

5) MOUNTING THE MOTOR FIG.C-C1

6) MOUNTING DRIVE ACCESSORIES FIG.D-D1

20 - ICARO SMART AC A2000 - ICARO ULTRA AC A2000

7) RACK CENTRING WITH RESPECT TO PINION FIG.J-K1-L

 **DANGER - Welding must be performed by a competent person issued with the necessary personal protective equipment as prescribed by the safety rules in force FIG.K.**

8) FASTENING LIMIT SWITCH BRACKETS FIG. E1-E2

The runners must lock the gate before this intercepts the mechanical backstops placed on the track. The closing end-of-stroke runner adjustment must be made in such a way as to leave a clearance of approximately 50mm between the gate and the fixed swing leaf, as prescribed by the current safety standards, otherwise fit an electric edge at least 50mm thick **FIG.N**.

9) STOPS FIG.M

 **DANGER - The gate must be fitted with mechanical stops to halt its travel both when opening and closing, thus preventing the gate from coming off the top guide. Said stops must be fastened firmly to the ground, a few centimetres beyond the electric stop point.**

10) MANUAL RELEASE (See USER GUIDE -FIG.2-).

Warning Do not JERK the gate open and closed, instead push it GENTLY to the end of its travel.

11) TERMINAL BOARD WIRING Fig. F-O

Once suitable electric cables have been run through the raceways and the automated device's various components have been fastened at the predetermined points, the next step is to connect them as directed and illustrated in the diagrams contained in the relevant instruction manuals. Connect the live, neutral and earth wire (compulsory). The mains cable must be clamped in the relevant cable gland (**FIG.O-ref.P1**), and the accessories' wires in the cable gland (**FIG.O-ref.P2**), while the earth wire with the yellow/green-coloured sheath must be connected in the relevant terminal (**FIG.O-ref.GND**).

FIG.O-ref.P3: limit switch wiring.

  **12) SEE THE CONTROL UNIT'S USER GUIDE FOR INFORMATION ON SETTING THE MOTOR'S PARAMETERS**

13) FASTENING THE COVER Fig. Q

14) WARNING!

Do not loosen or tighten the mechanical clutch nut (**FIG.P**).